

**AUTOMATIC SWITCHOVER
MANIFOLD
SERIES 3000**

Dual Regulators, Single Vent
Operation & Maintenance Manual

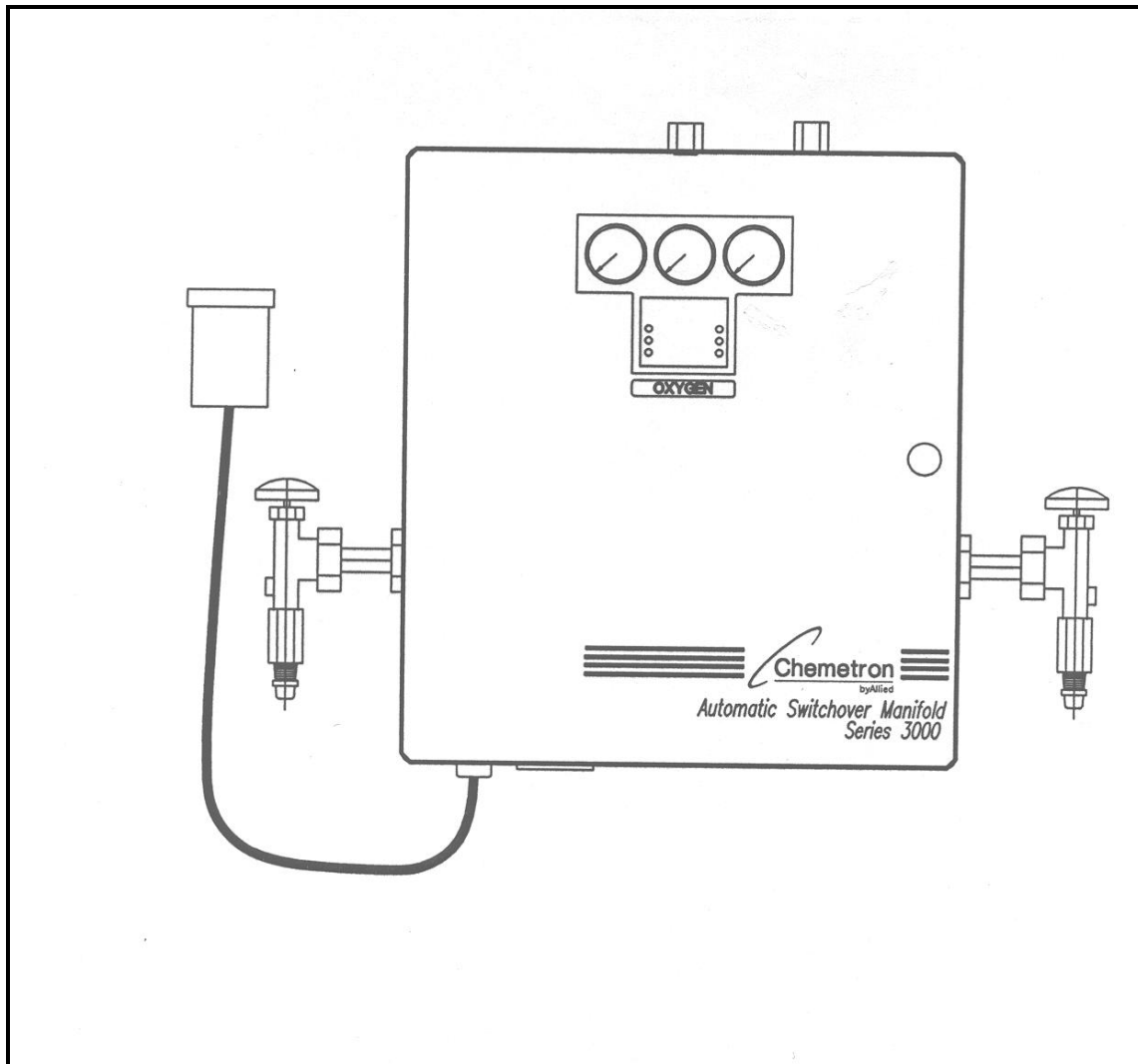

Allied Healthcare Products, Inc.
1720 Sublette Avenue - St. Louis, MO 63110
Telephone: 800-444-3954 - Fax: 314-771-1806
Catalog No. S188-292-001
Revision D



MANIFOLDS ARE AVAILABLE FOR THE FOLLOWING GASES:

- | | |
|--|---|
| <input type="checkbox"/> OXYGEN | <input type="checkbox"/> CARBON DIOXIDE |
| <input type="checkbox"/> NITROGEN | <input type="checkbox"/> MEDICAL AIR |
| <input type="checkbox"/> NITROUS OXIDE | <input type="checkbox"/> O ₂ /CO ₂ < 7% |

Table Of Contents

Subject	Page
Introduction _____	1
Key Elements _____	2
Manifold Operation	3
Factory Settings	4
Schematic Diagram	4
Flow Charts	5
Site Selection _____	6
Installation _____	7
Control Unit Outline	8
Method Of Operation	10
Safety Features	11
Remote Alarm Wiring Diagram _____	13
Leak Test	14
Ordering Information	15
Repair Parts List _____	19
Trouble Shooting _____	20
Limited Warranty	Back Cover



WARNING

ALL PRESSURE ADJUSTMENTS SHALL BE MADE BY AUTHORIZED PERSONNEL ONLY.
INCORRECT PRESSURES CAN DISRUPT GAS DELIVERY TO LINE.



WARNING

THE MANIFOLD SYSTEM MUST BE LOCATED IN A WELL VENTILATED AREA. NITROUS OXIDE CAN CAUSE UNCONSCIOUSNESS AND DEATH. OXYGEN AND $O_2/CO_2 < 7\%$ CAN GREATLY INTENSIFY A SPARK OR FIRE. CARBON DIOXIDE, NITROGEN, ARGON AND HELIUM CAN CAUSE SUFFOCATION.



CAUTION

DO NOT APPLY HEAT TO DELIVERY LINE UNION WHILE IT IS CONNECTED TO THE CONTROL UNIT. HEAT WILL HARM O-RINGS CAUSING LEAKS AND MALFUNCTIONS.



WARNING

DO NOT USE THREAD SEALANT ON ANY JOINT OR UNION. MOST SEALANTS CONTAIN HYDROCARBONS THAT CAN BE IGNITED BY HIGH PRESSURE OXIDIZING GASES.



WARNING

KEEP HANDS AND ALL PARTS CLEAN AND FREE OF OIL, GREASE OR ANY HYDROCARBON COMPOUND. HYDROCARBON COMPOUNDS CAN BE IGNITED BY OXIDIZING GASES.



CAUTION

ALL PRESSURE ADJUSTMENTS SHALL BE MADE BY AUTHORIZED PERSONNEL ONLY.
INCORRECT PRESSURES CAN AFFECT CYLINDER BANK SWITCHING & RESETTING WHICH CAN DISRUPT GAS DELIVERY.



CAUTION

DO NOT ATTEMPT TO RETROFIT THE CONTROL UNIT TO ACCOMMODATE OTHER GASES THAT THE CONTROL UNIT WAS NOT DESIGNED FOR.



WARNING

EACH CONTROL UNIT IS DESIGNED FOR USE WITH A SPECIFIC GAS AS INDICATED ON THE CONTROL UNIT. ANY ATTEMPTS TO ALTER ITS USE COULD RESULT IN SERIOUS INJURIES & FAILURE OF THE CONTROL UNIT.



CAUTION

THE HEALTH CARE FACILITY MUST HAVE PROCEDURES IN PLACE TO INSURE THAT DEPLETED CYLINDERS ARE REPLACED AS SOON AS POSSIBLE TO ASSURE A FRESH BANK AWAITS THE NEXT BANK SHIFT.



WARNING

SUDDEN RELEASE OF HIGH PRESSURE GAS CAN CAUSE BODILY INJURY.
ALWAYS BLEED DOWN PRESSURE SLOWLY. ALWAYS WEAR SAFETY GLASSES WHEN CHANGING CYLINDERS OR SERVICING UNIT.

Introduction

The dual line regulator Series 3000 Medical Gas Manifold has been cleaned, tested and prepared at the factory for the specific gas indicated. The unit complies with the National Fire Protection Association (NFPA) Specification 99-1999 "Nonflammable Medical Gas Systems". All critical connections are gas specific and are designed to eliminate supply gas errors.

This manual is supplied to give the health care facility personnel installation, operation and maintenance instructions. Keep this manual in the manifold door pocket for convenient reference.

The dual line regulator/single vent 3000 Medical Gas Manifold Control Unit will need right and left header bars and pigtailed that must be ordered separately. The installed system will automatically switch to the reserve bank when the primary bank is depleted. When the depleted cylinders are replaced with full ones the system will automatically reset itself in preparation for the next bank change. The primary side is the bank in use and the reserve side is the bank on "Reserve". This designation will automatically change from left to right and right to left as each bank is depleted and, in turn, refitted with full gas cylinders.

The empty LED indicator will show a depleted bank by turning red. A buzzer will also sound to indicate an empty bank or banks. When the system is reset, by replacing the depleted cylinders, the indicator will turn green and will also silence the buzzer. If the manifold is connected to the health care facility's central alarm system that will also indicate that the bank was depleted and, in turn, reset.

The only manual activity the Series 3000 Medical Gas Manifold requires is the changing of the depleted cylinders. The Series 3000 Manifold is available in six standard models, each specifically designed for its gas service. The gas standard services offered are: oxygen, nitrogen, nitrous oxide, medical air, O₂/CO₂ < 7% and carbon dioxide.

Manifolds may be obtained in these gas services as standard units. Most other medical gases can be obtained by special order. The manifold unit and header bar sections can be ordered complete by calling your Allied Sales Representative. Header bar sections can also be obtained by ordering the number and type needed to complete the manifold from the list on Page 15. NFPA requires at least the number of cylinders for an average twenty-four (24) hour day's supply per bank.

There are two methods of mounting the 3000 Manifold; either floor or wall (standard) systems. With the wall type, the control cabinet is attached to a wall bracket and cylinders stand next to the wall. The floor type may stand free, in the center of a room, with the control cabinet supported on a stand.

Three pressure gauges on the front of the control cabinet indicate left bank, right bank and line pressures.

Heater Kits are available as an option for use on nitrous oxide and carbon dioxide 3000 Manifolds where flow requirements are such that regulator frosting may cause pressure fluctuations.

	WARNING
REGULATORS MAY FREEZE UP IF THEY ARE USED AT HIGH FLOW RATES OR IN LOW TEMPERATURES WITHOUT A HEATER.	

Definitions

- Shall:** Is intended to indicate a requirement as stipulated by a standard or code.
- Should:** Is intended to indicate a recommendation or a suggestion or an item of advice, but not required.
- Note:** Is intended to indicate additional information that will be helpful.
- Caution:** Is intended to indicate that there is a slight chance of bodily injury or property damage. There is also the possibility of a manifold shutdown if the "Caution" is not heeded. This will be highlighted by an outline box.
- Warning:** Is intended to indicate that there is a moderate chance of bodily injury, death or property damage. This will be highlighted by an outline box.

Key Elements

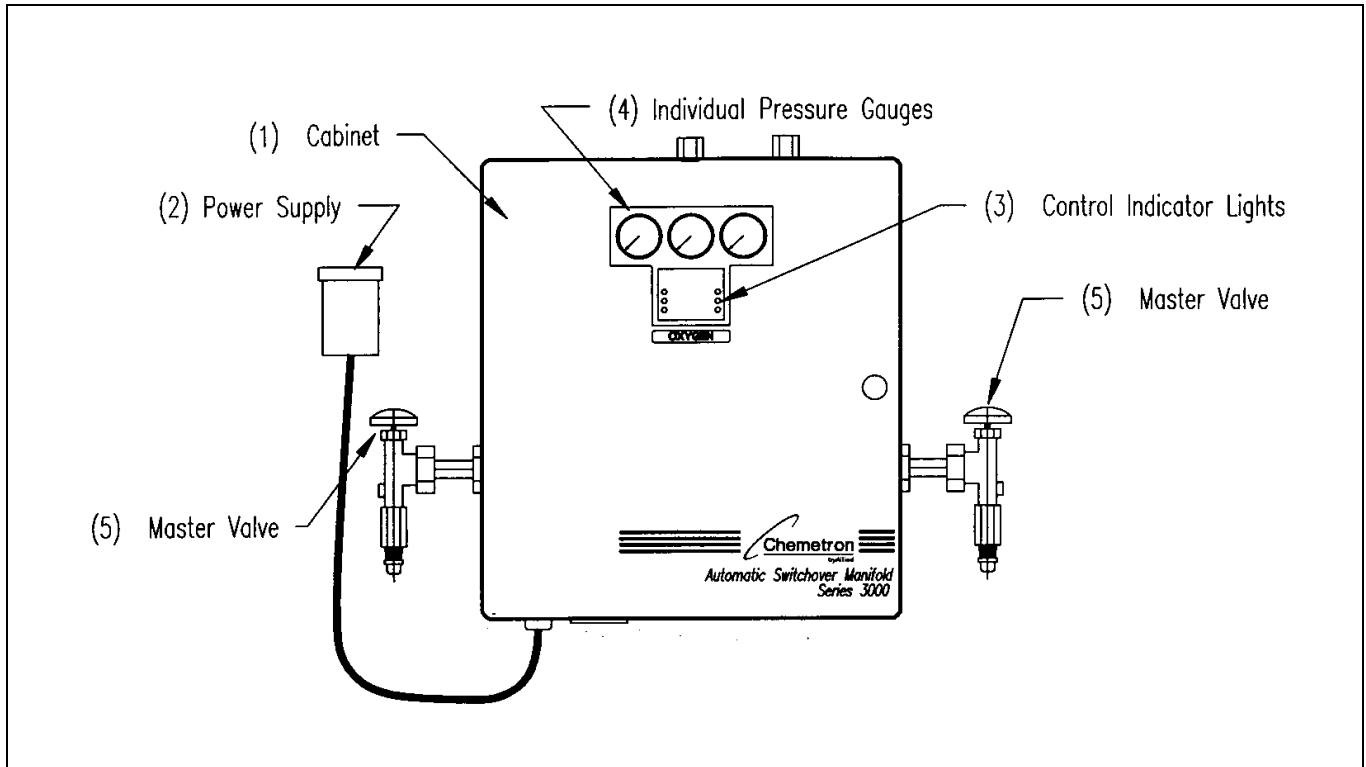

Figure 1

- A pressure control cabinet (1) that maintains constant pressure to the pipeline and enables smooth uninterrupted switchover from the “in use” to the “reserve” cylinders.
- A 115/230 VAC input, 24 VAC output power supply (2). Power supply includes dry contacts for local and remote alarm connections.
- Control panel indicator LED’s (3) indicate the status of the left and right cylinder banks. The “In Service” is indicated by the green LED while the reserve cylinder bank is indicated by the yellow “Reserve Ready” LED. A red “Replace Empty Cylinders” LED indicates a depleted cylinder bank.
- Individual pressure gauges (4) allow monitoring of left and right cylinder bank pressure, as well as, pipeline delivery pressure.
- Master valves (5) used to shut off gas in emergency situations, should normally be left open.
- Physical properties of manifold:

Dimensions (In inches): 24.0” H x 20.0” W x 9¼” D
Weight: 78 Lbs

Manifold Operation

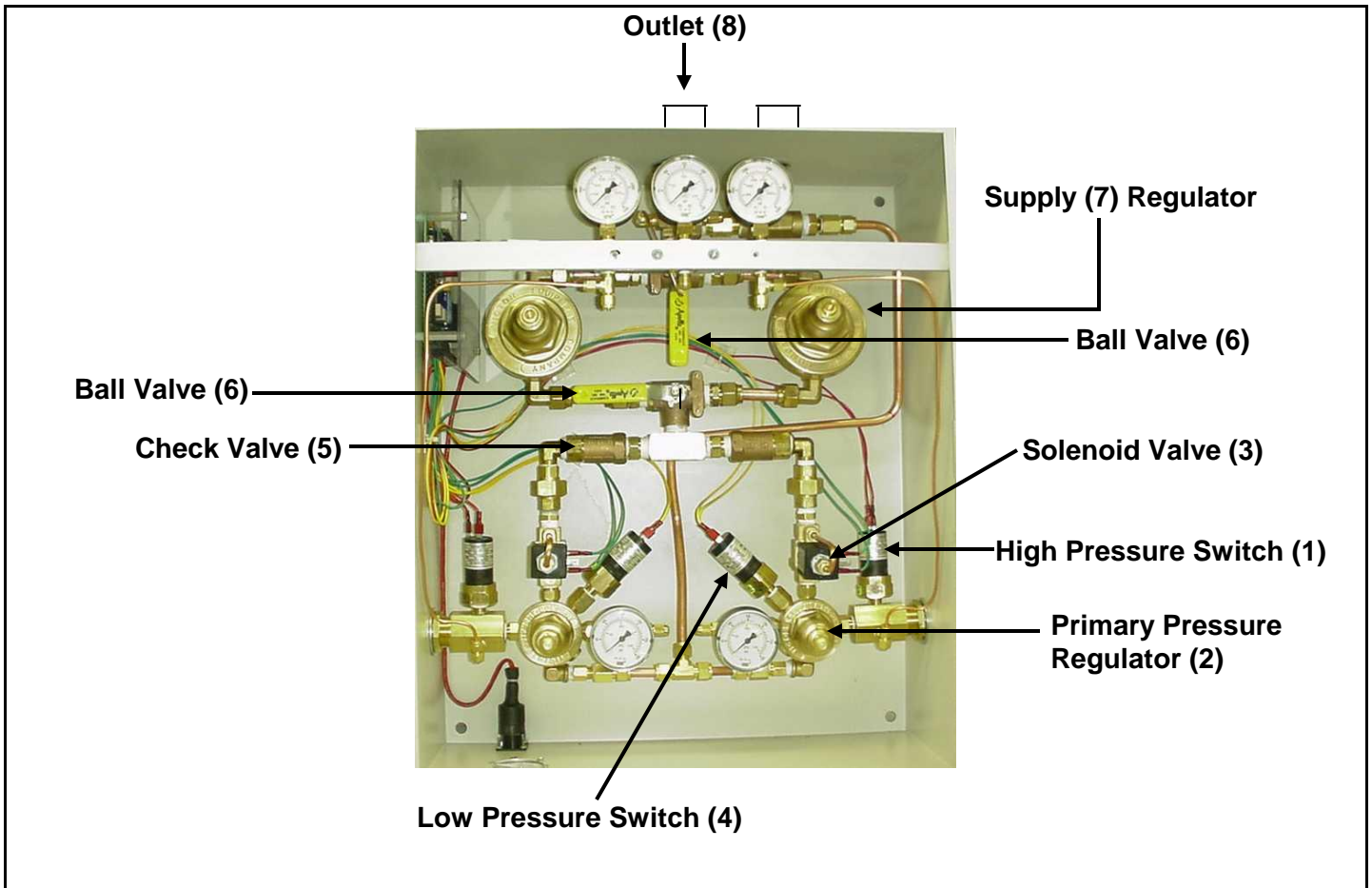

Figure 2

Gas Pressure flowing from a bank of cylinders into the manifold is measured by the high pressure switch (1) at the inlet adapter. The pressure is reduced as it flows through the primary pressure regulator (2) and out through a solenoid valve (3). This intermediate pressure is measured by a pressure switch (4) on the low pressure side of the primary regulator body. The gas then flows through a check valve (5) and into the ball valve (6). The ball valve directs the flow into either the left or right supply side regulator (7), where the pressure is reduced down to the present outlet pressure. The gas then flows through the supply line and out of the manifold into the pipeline distribution system (8). In the event of a power failure, the manifold solenoid valves automatically open and allow the flow of gas to the pipeline from both cylinder banks. When the power is re-established, the manifold will return to the status it had before the power interruption.

Cylinder Switchover

Switchover from the "Service" to "Reserve" side occurs when the "Service" side intermediate pressure falls below the set point of the low pressure switch. When the pressure drops below this set point, the "Reserve" side solenoid is opened and the empty solenoid valve is closed. The red "Replace Empty Cylinders" LED comes on. At this point, the green "In Service" LED on the "Reserve" side becomes illuminated. The "Reserve" bank automatically begins to flow without any interruption in service line delivery pressure. The red "Replace Empty Cylinders" LED and the low reading on the cylinder bank pressure gauge indicates which bank of cylinders is depleted and should be replaced with full cylinders. When either or both banks are empty, the local audible buzzer will sound. The buzzer will silence when both banks are filled with full cylinders. The buzzer can be silenced for maintenance purposes using the buzzer silencer located on the top left corner of the Main Control Board. The silencer will reset when both banks are filled with full cylinders. When the depleted cylinders are replaced with full ones, the yellow "Reserve Ready" indicator LED is illuminated.

Factory Settings

Pressure Switch Settings		
Low Pressure Switch	115 PSI	All gases except nitrogen
Low Pressure Switch	215 PSI	Nitrogen
High Pressure Switch	325 PSI	All gases

Relief Valve Settings		
Supply Line	75 PSI	All gases except nitrogen
Supply Line	270 PSI	Nitrogen
Primary Line	325 PSI	All gases

Regulator Settings		
High Regulator	250 PSI	All gases except Nitrogen
	275 PSI	Nitrogen
Low Regulator	55 PSI	All gases except Nitrogen
	180 PSI	Nitrogen

WARNING

ALL PRESSURE ADJUSTMENTS SHALL BE MADE BY AUTHORIZED PERSONNEL ONLY. INCORRECT PRESSURES CAN DISRUPT GAS DELIVERY TO LINE.

Schematic Diagram

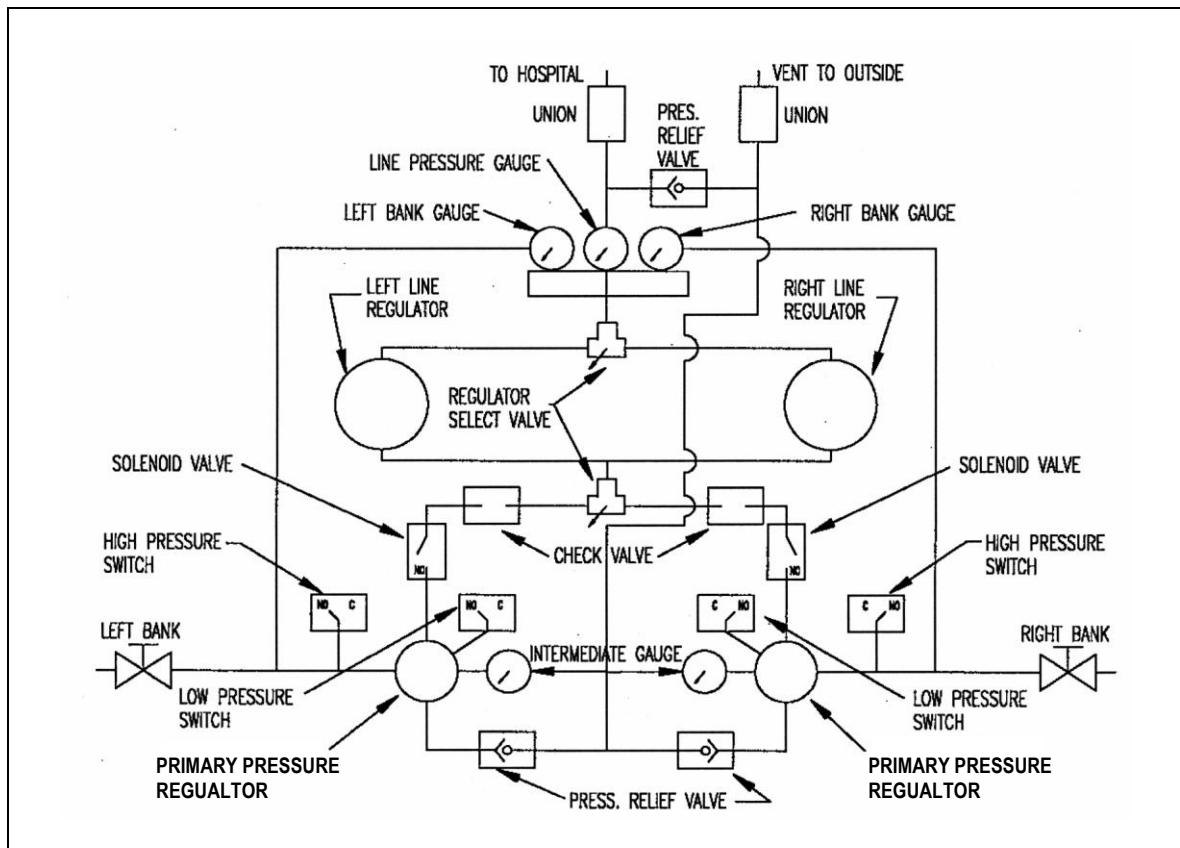

Figure 3 – Schematic Diagram

Flow Charts – 3000 Manifold

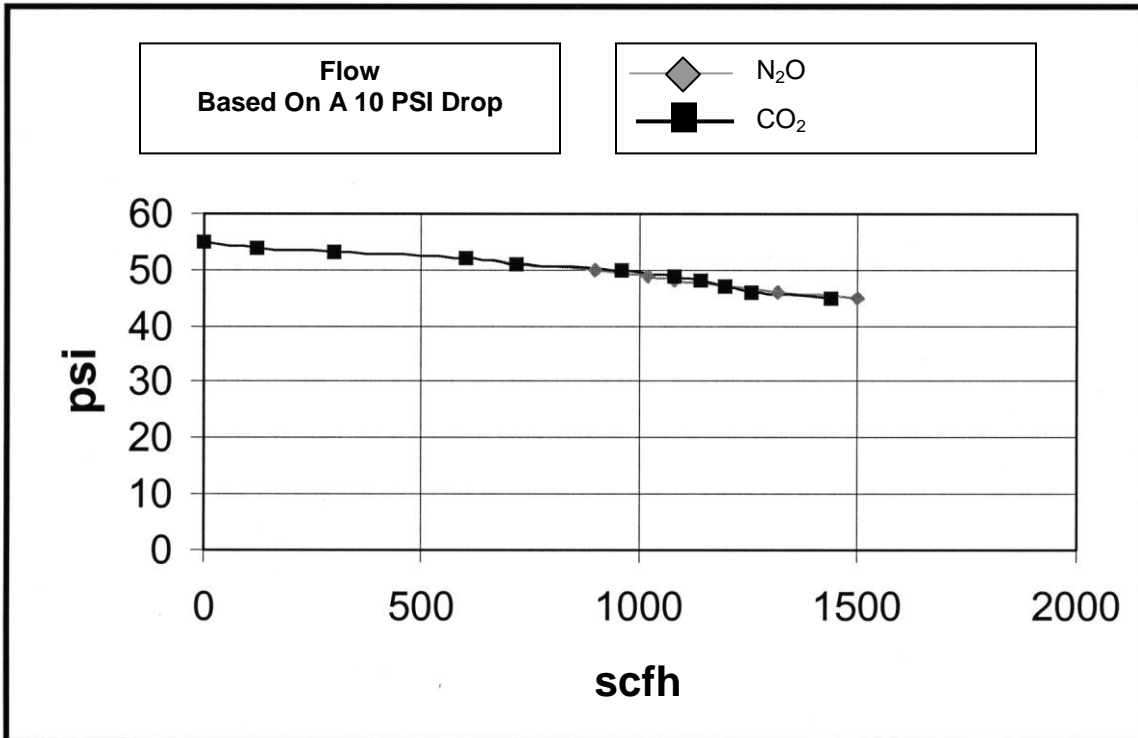
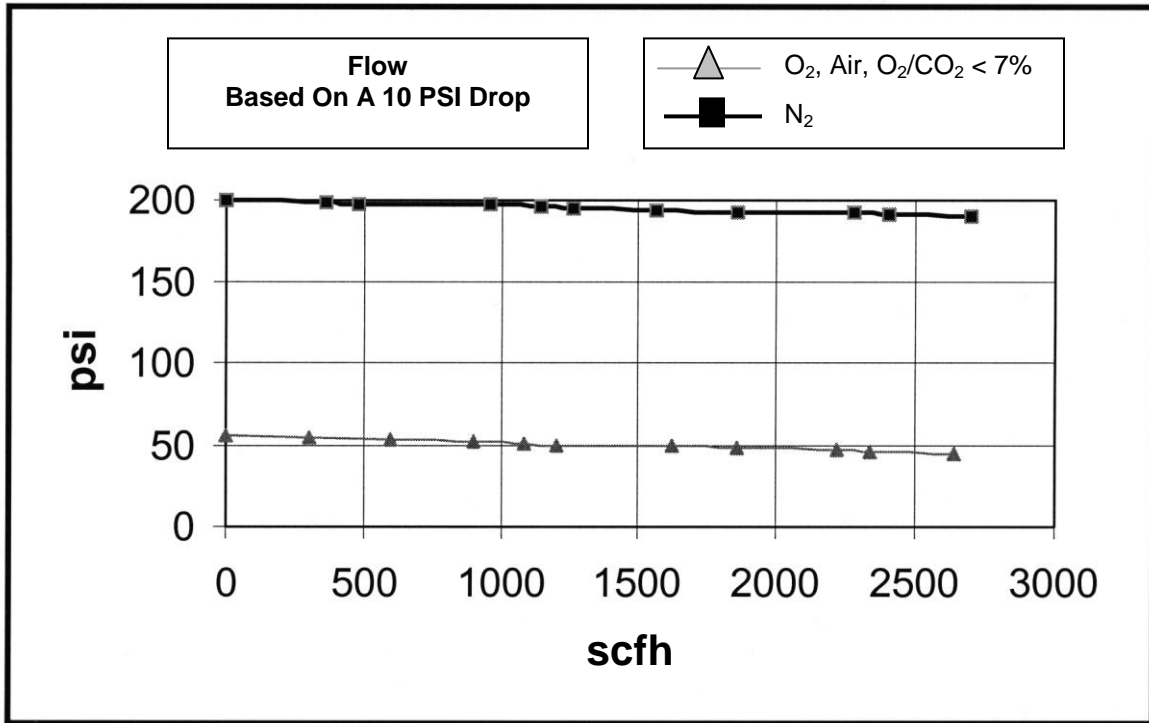

Figure 4

Site Selection

The proximity to the health care facility's central piping system is the obvious, but not the only, reason for choosing an installation site. Ventilation, temperature extremes, etc. must also be considered.

The manifold system shall be installed in a well ventilated area. None of the gas specific manifolds are designed for a flammable gas. Some of the gases will actively support combustion. The gases with high oxidizer content, such as oxygen, nitrous oxide and $O_2/CO_2 < 7\%$ shall never have grease, oil, or other combustibles come in contact with any part of the system. Also, tools and hands shall be kept clean and free of oil or grease. Spontaneous combustion may occur. There shall be no open flame in the manifold area. This includes matches, smoking material, pilot lights, etc. There shall be no spark generating equipment in the manifold area. This includes motors, switches, etc.

Even a gas as apparently harmless as nitrogen must be installed in a well ventilated area. If the nitrogen gas were allowed to build up to a point, in an unventilated area, where all the oxygen was pushed out, then a person entering this area would run the risk of suffocation. Both carbon dioxide and $O_2/CO_2 < 7\%$ gases contain carbon dioxide which is the primary waste gas the lungs try to exhale. The carbon dioxide in the blood must be removed before oxygen can be absorbed. Carbon dioxide inhaled in the air inhibits the lungs availability to remove carbon dioxide from the blood. As the carbon dioxide concentration increase so does the breathing difficulty. In the extreme case, a high concentration of carbon dioxide can cause the equivalent to suffocation even with some oxygen present.

Nitrous oxide is an anesthetic gas. It can cause unconsciousness and even death.

	<h2>WARNING</h2>
<p>THE MANIFOLD SYSTEM MUST BE LOCATED IN A WELL VENTILATED AREA. NITROUS OXIDE CAN CAUSE UNCONSCIOUSNESS AND DEATH. OXYGEN AND $O_2/CO_2 < 7\%$ CAN GREATLY INTENSIFY A SPARK OR FIRE. CARBON DIOXIDE AND NITROGEN CAN CAUSE SUFFOCATION.</p>	

The health care facility's central forced air heating and air conditioning system should never have a return duct connected to the manifold area. **The manifold area should always be vented to the outside away from any intake ducts.**

The manifold is designed to operate in a temperature range between 40° and 130°F. Relative humidity should not exceed 90%. If the humidity is high and the temperature is low, frost and/or ice could interfere with the performance of the regulators.

Allied Healthcare Products, Inc. (Allied) offers a set of header bar heater kits as an option with carbon dioxide and nitrous oxide control units that will preheat gas from the cylinders minimizing the frost problem.

Since carbon dioxide and nitrous oxide are both liquid when in the compressed gas cylinder, the phase change (from liquid to gas) cooling is added to the gas expansion cooling. Thus the frost will form much quicker with carbon dioxide and nitrous oxide than with nitrogen, oxygen, medical air, and $O_2/CO_2 < 7\%$. Under extreme conditions of high flow, the cylinders could become chilled to the point where droplets of liquid would pass down stream and harm the manifold and other health care equipment

Site selection should also take into consideration the handling convenience of the manifold and the loading docks are also important. **In the case of carbon dioxide and nitrous oxide the temperature shall not go below 65°F. A cylinder pressure of at least 325 PSI is required to automatically reset the manifold when the spent cylinders are replaced.**

Uncrating

All parts should be kept in their crates until they are needed for assembly. Check the gas type of the components to be sure they are the items ordered.

If damage is discovered during the uncrating and assembly process, contact the freight carrier and make a concealed damage report within seven (7) days. Allied will assist the claims process as much as possible, but it is the responsibility of the receiver to file any claims.

Minimum Equipment Needed

One Control Unit and a pair of corresponding cylinder header bars with pigtailed is the minimum equipment needed to have a functioning manifold system. Most systems will require more than a single cylinder per bank. Always install a balanced set of header bars for each manifold system, i.e. an equal number of cylinders per bank.

Adding header bars and gas cylinders to each bank will not increase the maximum flow rate of the system, but it will increase the time between cylinder changes, i.e. double the number of cylinders (and header bars) and the time between cylinder changes will be doubled.

Installation

The Series 3000 Manifold meets the provisions of the National Fire Protection Association (NFPA) Specification 99-1999. The installation of this manifold shall not deviate from these requirements. If local or special codes conflict with the NFPA requirements, the NFPA codes shall always prevail. If the code conflict cannot be resolved at the local level, contact Allied's Technical Support to determine if a waiver is feasible.

Control Unit

The Control Cabinet is designed to be water resistant, but it is not waterproof. The Control Cabinet should be mounted in a location protected from moisture. Suitable anchoring bolts will be necessary for mounting (bolts are not furnished with the unit, 7/16" diameter bolts are recommended). The Control Cabinet must be mounted to a sound structure where it is designed to handle the weight of the Control Cabinet. Keep the cabinet both horizontally and vertically level. If necessary, shim behind the back side.

Plumbing

Connect the delivery line union, located at the top center of the Control Unit, to the health care facility's central piping system. NFPA requires that a main shut off valve be installed between the delivery line union and the central piping system.

Be sure that the right and left header bar valves are turned off. Later in these Installation Instructions you will be advised when and how these valves should be used.

Control Unit Online

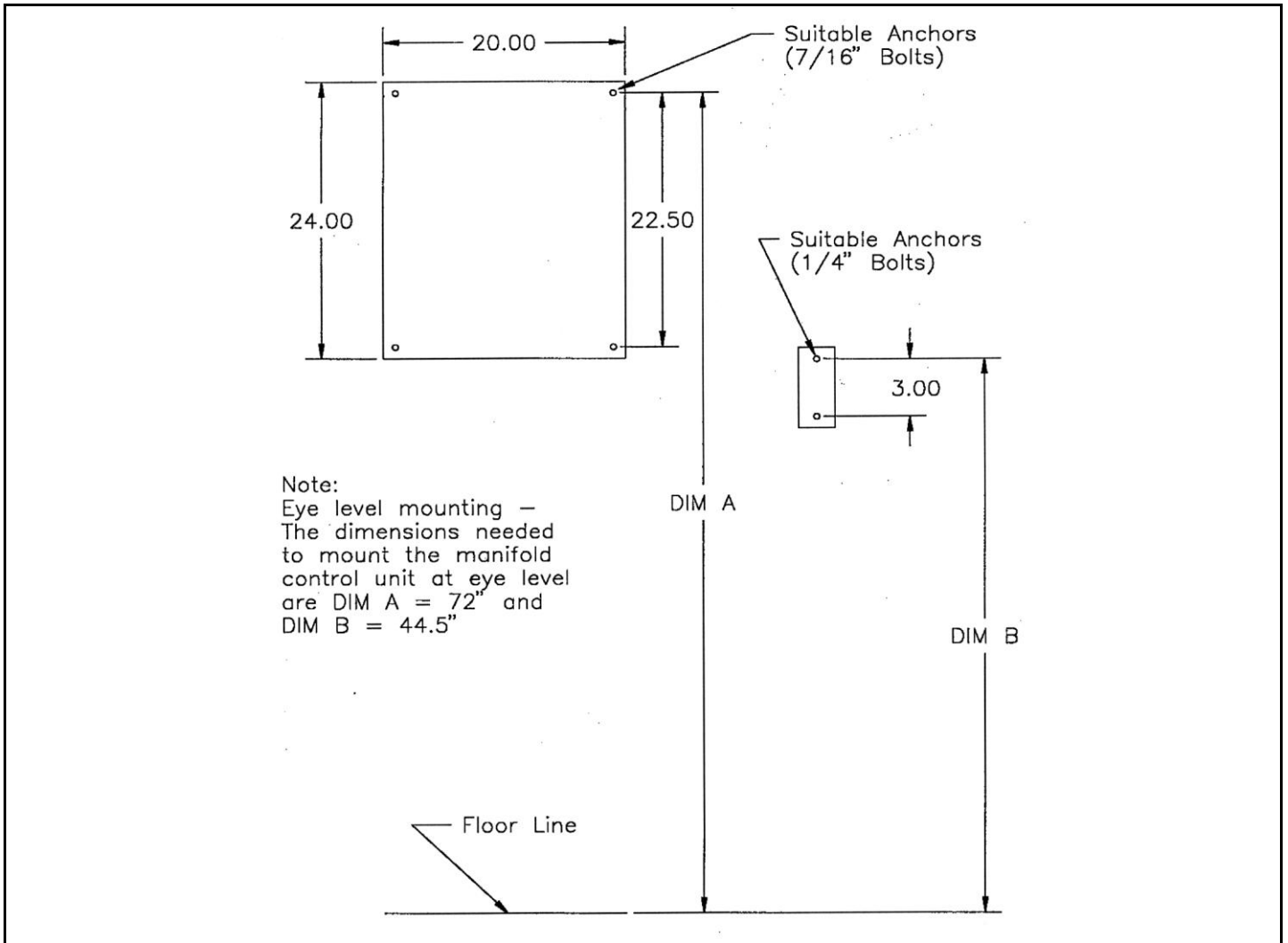

Figure 5

Approximate floor space needed to install manifold and header bar set.

Cylinder	Minimum Floor Space	Cylinder	Minimum Floor Space
1 X 1	4 Feet	6 X 6	14 Feet
2 X 2	6 Feet	7 X 7	16 Feet
3 X 3	8 Feet	8 X 8	18 Feet
4 X 4	10 Feet	9 X 9	20 Feet
5 X 5	12 Feet	10 X 10	22 Feet



CAUTION

**DO NOT APPLY HEAT TO DELIVERY LINE UNION WHILE IT IS CONNECTED TO THE CONTROL UNIT.
HEAT WILL HARM O-RINGS CAUSING LEAKS AND MALFUNCTIONS.**

Check for proper venting to atmosphere as required by job specifications and/or NFPA 99-1999, If the manifold is installed in an enclosed area, the safety relief valves must be vented to the outside atmosphere. On top of the control unit (to the right of the hospital supply line) a safety relief valve with a ½" NPT pipe union has been provided to attach a vent pipe. Provisions must be made to install this pipe to the outside atmosphere.

Electrical

The Manifold Series 3000 comes with a power supply box that can accommodate either 115 VAC or 230 VAC power input. See Figure 6 on Page 13 for a wiring diagram. In the event of a power failure, the manifold solenoid valves automatically open and allow the flow of gas to the pipeline from both cylinder banks. The manifold is designed to return to its previous stage via power re-establishment or emergency power.

Header Bars

Divide the total quantity of header bar sections into two groups, one for the left bank and the other for the right bank of cylinders. There should be an equal number of cylinder inlets on each side of the manifold.

After the Control Unit has been mounted, the header bars should be securely anchored to the wall (or Header Stand Kit) and carefully aligned and leveled. The union on each side of the bottom of the Control Unit provides for a gas specific header bar connection. Proper alignment is necessary to assure a leak free installation. Support all header bars with firmly anchored wall brackets (or Header Stand Kits).

Space the wall brackets (or Header Stand Kits) to conform to the side of the header bars. The first wall bracket (or Header Stand Kit) on either side of the Control Unit should be between the first two cylinder connections past the header bar elbow assembly. A wall bracket (or Header Stand Kit) should be placed every third cylinder connection thereafter. If the manifold system purchased has two or less cylinder connections per side, no wall brackets (or Header Stand Kits) are needed.



WARNING

**DO NOT USE THREAD SEALANT ON ANY JOINT OR UNION. MOST SEALANTS CONTAIN
HYDROCARBONS THAT CAN BE IGNITED BY HIGH PRESSURE OXIDIZING GASES.**

Connect the header bar assembly and header elbow to the master header valve fitting on the Control Unit. Use one wrench on the Control Unit inlet connection and another on the header elbow nut. Hold the Control Unit inlet connection steady and tighten the header elbow nut. This will prevent any twisting of internal components of the Control Unit. Twisting of internal components may cause leaks.

Check the alignment and level of the Control Unit and header brackets. If there is an alignment problem loosen all the header bar mounting hardware. Adjust as needed and tighten.

Heated Header Bars

The physical characteristics and flow performance of nitrous oxide and carbon dioxide often create the need to heat the gas as it passes through the header bar or Control Unit. Low ambient temperature, high gas flow, and ambient high dew point will have a negative effect on the performance of any manifold. Allied offers a heated header bar that adapts easily to any existing or new manifold installation. See Installation Instructions provided with heated header bars.

Note: In order for the heater kits to be effective when used in CO₂ or N₂O service, they must be installed between the header bars and the Control Unit.

Cylinder Pigtails

Allied offers two styles of flexible pigtailed: coiled copper (oxygen) and braided stainless steel (all other gases). Refer to the Optional Equipment Section or contact your Allied Sales Representative. The braided pigtail offers greater ease of handling the gas cylinders. Both styles of pigtailed have built in check valves. The pigtail end that has the check valve is denoted by stamping on one of the flats of the CGA gas specific nut and/or a label indicating direction of flow. The direction of flow is from the cylinder to the header bar.

Note: When installing the pigtailed to the header bars be sure to note the flow direction of the pigtail.

Cylinders

Before pressuring the header bars, make sure all pigtailed are properly connected. Remove the protective cylinder caps from the cylinders and store in a safe place for later use. Place and secure the cylinders in position. Connect each pigtail to a cylinder and tighten with a wrench.

For additional information regarding the handling of gas cylinders, refer to the Compressed Gas Association (CGA) Pamphlet P-2, Section 4.1 for General Rules, Section 4.2 for Moving Cylinders and 4.3 for Storing Cylinders.

	WARNING
KEEP HANDS AND ALL PARTS CLEAN AND FREE OF OIL, GREASE OR ANY HYDROCARBON COMPOUND. HYDROCARBON COMPOUNDS CAN BE IGNITED BY OXIDIZING GASES.	

Method Of Operation

The 3000 Manifold delivers a regulated gas pressure through a wide range of flow rates to the health care facilities central gas piping system. The source of the gas is two banks of high pressure cylinders (usually H size). When a bank is depleted, the 3000 Manifold will automatically switch to the fresh bank delivering an uninterrupted gas supply to the health care facility. Change over shall be performed by solenoid valves contained in the control cabinet. In the event of an electrical power failure, both solenoid valves shall automatically open to provide an uninterrupted gas flow. The manifold Control Unit should not require any manual resetting or adjustments except for the replacement of depleted cylinders.

Under normal operating conditions, the gas will leave the high pressure cylinders through the pigtailed into the header bars. The pigtailed have one way valves (check valves) to allow the replacement of depleted cylinders without gas pressure back flow into the remaining depleted cylinders on the bank. In the event a safety relief device on an individual cylinder should activate or a pigtail should leak excessively, the local check valve will also prevent loss of gas from the rest of the cylinders on that bank.

The gas flows through the header bar to the Control Unit. A manually operated shut off valve is installed downstream of each header bar. There are two of these valves located outside the control cabinet, one on the right and one on the left side. These valves are normally left fully open to allow unrestricted flow of gas from the two cylinder banks. In case of an emergency, they can be closed to isolate one or both banks.

The gas flows through the manually operated shut off valve into the primary regulator. This regulator reduces the high cylinder pressure to an intermediate pressure. The intermediate pressure gas flows through the solenoid valve to the line regulator for its final (line) pressure reduction for use in the health care facility. Two line pressure regulators are installed in parallel and each is capable of maintaining a constant dynamic delivery pressure at the maximum designed flow rate of the system. Only one line regulator is in service at any given time and the other is held in reserve. The reserve regulator can be serviced if necessary.

We recommend that the line regulators alternate actively supplying pressure to the piping system on a monthly basis. This means that each line regulator will have one month of active service followed by one month of rest.

Pressure relief valves are installed down stream of all pressure regulators and are set at no more than 50% above the setting of the pressure regulator located immediately upstream. All the pressure relief valves are capable of fully relieving the pressure at the set point. All pressure relief valves are piped together to allow for the installation of a single vent line leading outside.

The solenoid valve is the key “automatic” mechanism in the 3000 Manifold. It is the bank switching control that assures the uninterrupted flow of gas at an unfluctuating delivery pressure. When the operating bank pressure falls to a predetermined level, which is controlled by the preset pressure switches (high and low), the switches will activate the electronic control board causing the system to switch to the fresh (reserve) cylinder bank.

	<h2>CAUTION</h2>
<p>ALL PRESSURE ADJUSTMENTS SHALL BE MADE BY AUTHORIZED PERSONNEL ONLY. INCORRECT PRESSURES CAN AFFECT CYLINDER BANK SWITCHING AND RESETTING WHICH CAN DISRUPT GAS DELIVERY.</p>	

The 3000 Manifold control cabinet has three means of providing continuous status information on the system. First, pressure gauges to indicate the bank pressures and the delivery pressure. Second, six (6) indicator LED's, two (2) green that indicate cylinder in use, two (2) yellow for Reserve Ready and two (2) red that indicate that a bank is now depleted. Third, a loud 90 db's (with manifold door open standing 3 feet away) audible buzzer to give an alarm when either or both banks are depleted.

Bank Change Over Indicators

The six (6) indicators are controlled by sensing the bank pressure. Replacing the depleted cylinders resets the system, changing the indicator from red to green. At the same time the yellow LED will change to green to go from Reserve Ready to In Service. Both red LED's will show green prior to initial pressurization or whenever both cylinder banks are below the preset valve. Switchover will occur when the supply pressure falls below 115 PSI and will go from empty to reserve when the supply pressure reaches 325 PSI.

Alarm Systems

Allied carries a complete line of alarm systems which can be used in conjunction with the 3000 Manifold to provide the required visual and audible signals, in suitable locations, when bank switching occurs.

For remote alarm electrical connection, use Electrical Wiring Drawing shown on Figure 6. The 3000 Manifold System, when used in conjunction with these alarm systems, complies with CSA Z305.1-M1984. However, since these alarm systems are external to the manifold, they are not dealt with in detail in this manual.

Safety Features

Each 3000 Manifold is clearly labeled for the only gas it is factory assembled for. A large nameplate is affixed to the cabinet. The system is gas specific from the control unit to the cylinder end of the pigtails. Both solenoid valves will automatically open upon an electrical power failure.

As soon as one or more fresh cylinders are connected to a cylinder bank, the solenoid valve will automatically shift to that bank and resume gas flow to the piped system.

Function Identification

The bank LED's and pressure gauges on the cabinet face are clearly marked to explain their function.

The 3000 Manifold header bars are designed to assure that only cylinders containing the proper gas can be connected to them. All header bar connections and pigtails comply with CGA Standards.

	CAUTION
DO NOT ATTEMPT TO RETROFIT THE CONTROL UNIT TO ACCOMMODATE OTHER GASES THAT THE CONTROL UNIT WAS NOT DESIGNED FOR.	

	WARNING
EACH CONTROL UNIT IS DESIGNED FOR USE WITH A SPECIFIC GAS AS INDICATED ON THE CONTROL UNIT. ANY ATTEMPTS TO ALTER ITS USE COULD RESULT IN SERIOUS INJURIES AND FAILURE OF THE CONTROL UNIT.	

	CAUTION
THE HEALTH CARE FACILITY MUST HAVE PROCEDURES IN PLACE TO INSURE THAT DEPLETED CYLINDERS ARE REPLACED AS SOON AS POSSIBLE TO ASSURE A FRESH BANK AWAITS THE NEXT BANK SHIFT.	

	WARNING
SUDDEN RELEASE OF HIGH PRESSURE GAS CAN CAUSE BODILY INJURY. OPEN VALVES SLOWLY. ALWAYS BLEED DOWN PRESSURE SLOWLY. ALWAYS WEAR SAFETY GLASSES WHEN CHANGING CYLINDERS OR SERVICING UNIT.	

Remote Alarm Wiring Diagram

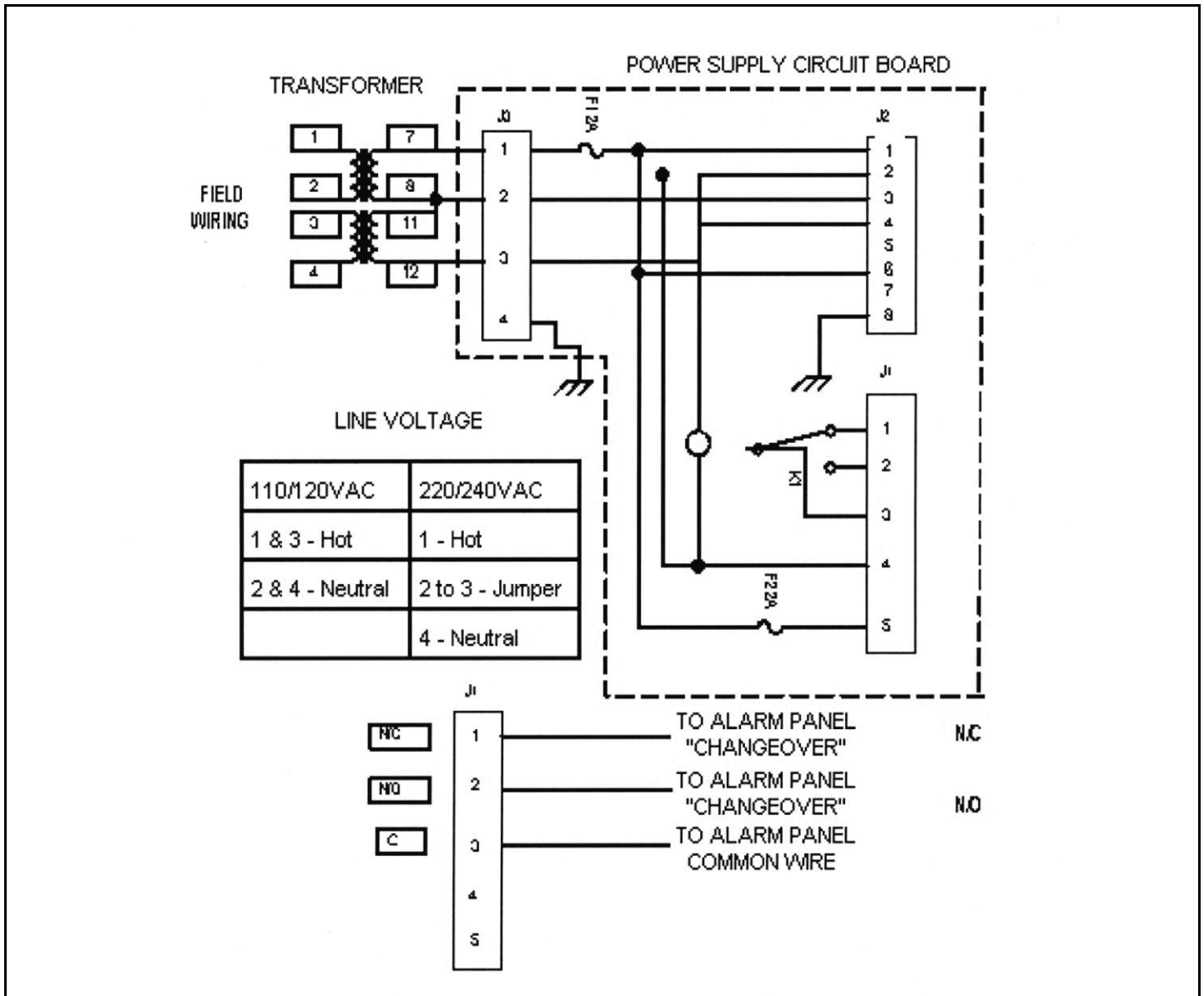

Figure 6

Current drawn on primary side of transformer is .12 amps and peaks at 1.28 amps for 115 VAC input

Leak Test

In order to determine whether any leaks exist between header bar sections or at the central pipe system connection, the system must be pressurized. Either oil-free dry air or oil-free dry nitrogen may be used for new installations. In the case of either a medical air or nitrogen 3000 Manifold, the actual service gas may be used to perform the leak tests. In the case of oxygen, nitrous oxide, carbon dioxide or O₂/CO₂ < 7% 3000 Manifolds, the actual service gases are not suitable for leak testing due to their inherent dangerous properties.

The following steps should be followed to leak test the 3000 Manifold:

1. Shut off the flow at the outlet of the pressure control cabinet.
2. Shut off all cylinders supplying pressure to the supply headers.
3. Monitor pressure on the three gauges on the pressure control cabinet.
4. If any of the gauges drop in pressure, a leak is occurring.
5. Leaks may be detected audibly, or an approved leak detector solution may be used.
6. If a leak detector solution is used to detect leaks inside the pressure control cabinet, use caution to ensure the solution does not get into electrical components.
7. If leaks are detected, bleed all pressure from the manifold before repairing the leak.
8. Leaking joints utilizing metal-to-metal seals should be disassembled and examined. If dents, scratches, or other damage to the seals are the cause of the leak, the damaged components should be replaced and the manifold connection properly reassembled.
9. Leaking joints, utilizing pipe threads should have the threaded component removed, the old tape removed, and new Teflon tape applied to the threads. The component should then be reinstalled, the manifold re-pressurized, and then be retested for leaks.
10. Leaking joints utilizing o-ring seals should be disassembled and the o-ring examined. If the o-ring is cut, dented, or otherwise damaged, the o-ring should be replaced, the joint reassembled, the manifold re-pressurized, and the joint retested for leaks.
11. All leaking components must be repaired or replaced.

All joints must be pressure tested again using the above procedures.

When there are no leaks, bleed the system and remove the test cylinders, pigtailed and gas adapters. The system is now ready to accept cylinders of the proper gas and service the health care facility needs.

If gas conversion adapters were used to test the manifold system, it is important that the gas conversion adapters and the nitrogen or medical air pigtailed be removed from the area. Every precaution must be taken to prevent hazardous gas mixing by accidentally using these test adapters.

Ordering Information

The Series 3000 Manifold has two (2) outlet (line) regulators and one (1) safety relief vent. The Series 3000 Manifold will shift banks automatically and will automatically reset when the depleted cylinders are replaced.

Catalog Numbers	System	Gas
86-61-2100	Control Unit Only	Oxygen
86-63-2100	Control Unit Only	Nitrous Oxide
86-64-2100	Control Unit Only	Medical Air
86-65-2100	Control Unit Only	Carbon Dioxide
86-66-2100	Control Unit Only	Nitrogen
86-67-2100	Control Unit Only	O ₂ /CO ₂ < 7%

A complete system must have one Control Unit and one pigtail per cylinder and one header bar inlet per cylinder. Header bars must be used in pairs to assure a balanced system, i.e. right and left banks with an equal number of cylinders. For your convenience, we have balanced sets of header bars available (see Page 15). If a custom header bar set is needed, we have individual header bar sections available (see Page 16) that may be mixed and matched as needed to obtain the cylinder count desired. The following schematic was chosen to show the general configuration of a system, the specific header bar sequence should be chosen based on the average anticipated flow vs. cylinder depletion time and location needs.

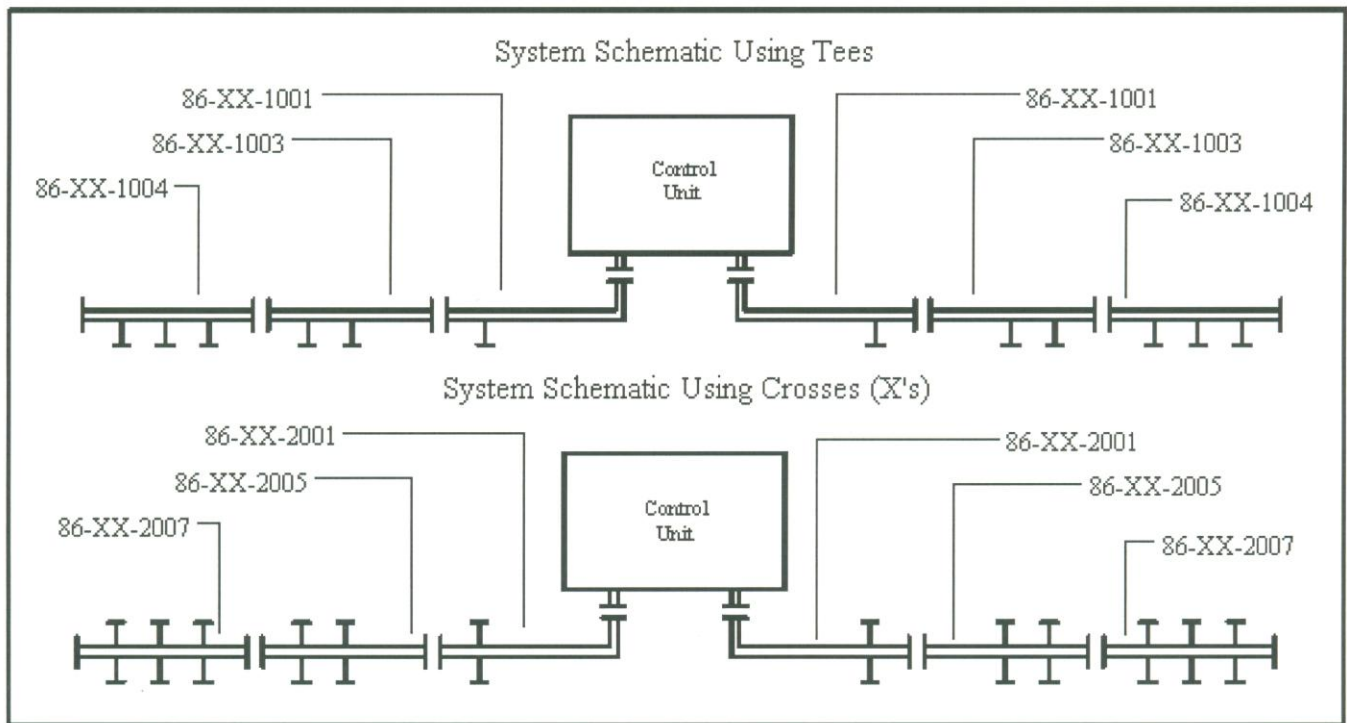

When ordering header bar sections or sets, replace the "XX" with one of the following gas code numbers.

51 for Oxygen
54 for Medical Air
56 for Nitrogen

53 for Nitrous Oxide
55 for Carbon Dioxide
57 for O₂/CO₂ < 7%

If the sections below are to be used to expand a system, they must be ordered in pairs to assure a balanced system, i.e. right and left banks with an equal number of cylinders. Each section also needs a pigtail with an equal number of cylinders. Each section also needs a pigtail for each cylinder. End caps/plugs should be ordered as needed.

Catalog Numbering System For Header Bar Sections

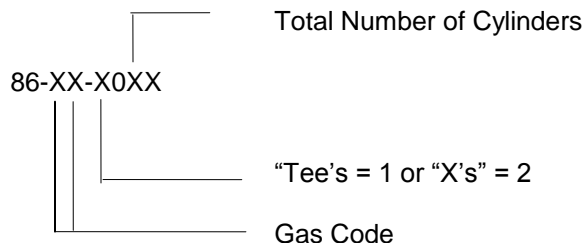

INDIVIDUAL HEADER BAR SECTIONS

CATALOG NUMBERS	HEADER BAR DESCRIPTION	SCHEMATIC FORM
86-XX-1001	WITH TEE 7 ELBOW FOR 1-2 CYLINDERS	
86-XX-1002	WITH TEE FOR 1-2 CYLINDERS	
86-XX-1003	WITH TEE FOR 2-3 CYLINDERS	
86-XX-1004	WITH TEE FOR 3-4 CYLINDERS	
86-XX-1005	WITH TEE FOR 4-5 CYLINDERS	
86-XX-2001	WITH X & ELBOW FOR 2-3 CYLINDERS	
86-XX-2003	WITH X'S FOR 2-3 CYLINDERS	
86-XX-2005	WITH X'S FOR 4-5 CYLINDERS	
86-XX-2007	WITH X'S FOR 6-7 CYLINDERS	
86-XX-1007	ELBOW ONLY	
86-58-005X	THREADED END CAP/PLUG WITH CHAIN	
86-58-001X	FLEXIBLE PIGTAIL WITH CHECK VALVE	
86-58-002X	COPPER PIGTAIL WITH CHECK VALVE	

When ordering header bar sections or sets, replace the "XX" with one of the following gas code numbers.

51 for Oxygen
 54 for Medical Air
 56 for Nitrogen

53 for Nitrous Oxide
 55 for Carbon Dioxide
 57 for O2/C02 < 7%

HEADER BAR HEATER KIT

Provides heat directly to gases and prevents liquids and ice crystals from entering and damaging manifold control under adverse conditions and/or high demand periods of operation. Available in 1,000 cubic feet per hour (watts) for nitrous oxide or carbon dioxide service. 120 Volts power required to each unit. All units are temperature controlled. Attaches to existing header bars without increasing space requirements.

Catalog Numbers:

86-53-1013	1,000w	N ₂ O
86-55-1013	1,000w	CO ₂

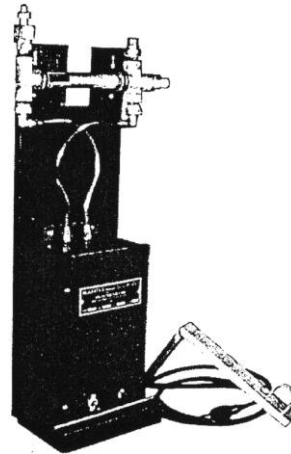

STAINLESS STEEL BRAIDED PIGTAILS

High pressure reinforced Teflon hose consisting of one inner stainless steel braid, two layers of stainless steel spiral wrap plus an outer braid of stainless steel. Specifications include minimum bend radius of 3-inches, maximum operating pressure of 3,000 PSI, CGA fittings attached to the tubing are brass.

Catalog Numbers:

N/A	O ₂
86-58-0013	N ₂ O
86-58-0014	Medical Air
86-58-0015	CO ₂
86-58-0016	N ₂
86-58-0017	O ₂ /CO ₂ < 7%



FREE STANDING SUPPORT

Provides a means of support when space dictates non-wall mounting. Mounting height is pre-determined. Support angles are 1½. Inch aluminum angle bolted to frame members. Some assembly is required.

Catalog Numbers:

86-61-0038	Floor Mount Control Unit Stand
86-61-0039	Header Stand Kit – Quantity 2 (Order one kit for every six (6) cylinders on a manifold)

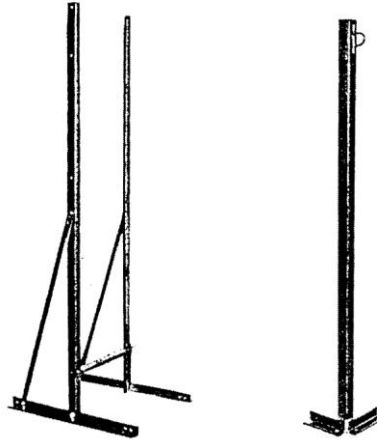

ELBOW ASSEMBLIES

Allows header bars to negotiate corners when space is not sufficient for complete manifold to be mounted to wall.

Elbow measure: 3" X 4"

Catalog Numbers:

86-51-1007	O ₂
86-53-1007	N ₂ O
86-54-1007	Medical Air
86-55-1007	CO ₂
86-56-1007	N ₂
86-57-1007	O ₂ /CO ₂ < 7%



Repair Parts List

Catalog No.	Description	Gas	Qty. Per Kit
86-90-2541	Line Pressure Relief Valve	Oxygen & O ₂ /CO ₂ < 7%	1
86-90-2999	Line Pressure Relief Valve	Nitrous Oxide, Carbon Dioxide & Medical Air	1
86-90-3000	Line Pressure Relief Valve	Nitrogen	1
86-90-3001	High Pressure Hand Valve	Oxygen	1
86-90-3002	High Pressure Hand Valve	Nitrous Oxide	1
86-90-3003	High Pressure Hand Valve	Medical Air	1
86-90-3004	High Pressure Hand Valve	Carbon Dioxide	1
86-90-3005	High Pressure Hand Valve	Nitrogen	1
86-90-3006	High Pressure Hand Valve	O ₂ /CO ₂ < 7%	1
86-90-3007	0-5000 PSI Bottom Mount Gauge	All	1
86-90-3008	0-100 PSI Bottom Mount Gauge	All Except Nitrogen	1
86-90-3009	0-300 PSI Bottom Mount Gauge	Nitrogen	1
86-90-3010	0-300 PSI Back Gauge	All	1
86-90-3011	High Pressure Switch	All	1
86-90-3012	Low Pressure Switch	All Except Nitrogen	1
86-90-3013	Low Pressure Switch	Nitrogen	1
86-90-3014	High Pressure Regulator Complete	All	1
86-90-3015	High Pressure Relief Valve	Oxygen & O ₂ /CO ₂ < 7%	1
86-90-3016	High Pressure Relief Valve	Nitrous Oxide, Carbon Dioxide & Medical Air	1
86-90-3017	High Pressure Relief Valve	Nitrogen	1
86-90-3018	High Pressure Regulator Repair Kit	All	1
86-90-3019	Solenoid Valve Complete	Oxygen & O ₂ /CO ₂ < 7%	1
86-90-3020	Solenoid Valve Repair Kit	Oxygen & O ₂ /CO ₂ < 7%	1
86-90-3021	Solenoid Valve Complete	Nitrous Oxide, Nitrogen, Carbon Dioxide & Medical Air	1
86-90-3022	Solenoid Valve Repair Kit	Nitrous Oxide, Nitrogen, Carbon Dioxide & Medical Air	1
86-90-3023	Solenoid Coil	All	1
86-90-3024	Check Valve Complete	Oxygen & O ₂ /CO ₂ < 7%	1
86-90-3025	Check Valve Complete	Nitrous Oxide, Nitrogen, Carbon Dioxide & Medical Air	1
86-90-3026	3-Way Ball Valve Complete	All	1
86-90-3027	Line Regulator Complete	All Except Nitrogen	1
86-90-3028	Line Regulator Repair Kit	All	1
86-90-3029	Line Regulator Complete	Nitrogen	1
86-90-3031	Wiring Harness & Switches, Complete	All	1
86-90-3032	Wiring Harness, Control Board	All	1
86-90-3033	Wiring Harness, LED's	All	1
86-90-3034	LED, Green	All	1
86-90-3035	LED, Yellow	All	1
86-90-3036	LED, Red	All	1
86-90-3037	Electronic Control Board	All	1
86-90-3038	Power Supply Complete	All	1
86-90-3039	Wiring Harness, Power Supply	All	1
86-90-3040	Fuse, Power Supply	All	1

Trouble Shooting

This section is intended to serve as a general guide for identifying the potential functional problems which could occur in the operation of the manifold.

Only some minor checks and repairs are recommended to be made in the field.

Components removed from the manifold system for maintenance must be serviced, repaired and tested by properly qualified medical service personnel only. Original manufacturer's parts, as supplied by Allied, must be used in the maintenance of manifolds.

Trouble	Probable Cause	Remedy or Check
<p>Indicator Faults</p> <p>Empty indicator LED shows red after depleted cylinders have been replaced.</p> <p>Empty indicator LED does not turn red when one tank is depleted and change over occurs.</p> <p>The pressure switch does not respond to the replacement of depleted cylinders with fresh cylinders.</p>	<p>Faulty wiring</p> <p>Bad LED</p> <p>Bad high pressure switch</p> <p>Faulty wiring or loose connections</p> <p>Bad LED</p> <p>Bad low pressure switch</p> <p>Solenoid valve/coil</p> <p>Faulty switch</p>	<p>Check for loose connections and wiring harnesses.</p> <p>Replace LED</p> <p>Check for loose connections. Check high pressure gauge and make sure it reads above 325 PSI. Replace switch if necessary.</p> <p>Check for loose connections and check wiring harness.</p> <p>Replace LED</p> <p>Check for loose connections. Check intermediate pressure gauge and make sure it reads below 115 PSI during switchover. Replace switch if necessary.</p> <p>Check for loose connections. Verify with Volt meter that when closed/ energized it reads 24 VAC.</p> <p>Check for loose connections and wiring harnesses. Check high pressure gauge to ensure that it is above the preset value.</p>
<p>Primary Regultor Faults</p> <p>Gas leakage around primary pressure regulator body cap.</p> <p>Relief valve venting</p>	<p>Loose cap</p> <p>Diaphragm leak</p> <p>Over pressure due to creeping or faulty regulation caused by damaged regulator seat.</p> <p>Over pressure due to damaged regulator diaphragm.</p>	<p>Turn off all power to the control unit and bleed down system. Tighten cap.</p> <p>Replace regulator with substitute unit. Replace diaphragm with Regulator Repair Kit.</p> <p>Replace regulator with substitute unit. Replace seat assembly with Regulator Repair Kit.</p> <p>Replace regulator with substitute unit. Replace diaphragm with Regulator Repair Kit.</p>

Trouble	Probable Cause	Remedy or Check
Line Pressure Regulator Faults		
Over pressure alarm set off	Line regulator set too high	Set line regulator to the pressure specified.
	Defective line regulator	If regulator will not respond to adjustments, repair regulator with repair kit or replace regulator unit. Switch to alternate line regulator.
Under pressure alarm set off	Line regulator set too low	Set line regulator to the pressure specified.
	Defective line regulator	If regulator will not respond to adjustments, repair regulator with repair kit or replace regulator unit. Switch to alternate line regulator.
	Excessive flow demand	Look into efficiency methods to reduce the flow requirements. If system requirements exceed 2700 SCFM, then a second manifold system is needed.
Unusual loss of cylinder pressure in supply bank	Leak in the central piping system	Check and repair as necessary.
	Leak in headers or pigtails	Check and tighten all connections as necessary.
	Safety relief valves are opened	Check for correct settings of valves and replace relief valves (high or low) if necessary.
Required gas flow not available	Line regulator not set correctly	Set line regulator to the pressure specified.
Solenoid Valve Faults		
Solenoid valve switches before operating bank is depleted	Faulty electrical connections on solenoid valve	Check loose connections and repair as necessary.
	Faulty electrical connections on low pressure switch	Check loose connections and repair as necessary.
	Bad solenoid valve/coil	Check and repair with Solenoid Valve Kit as necessary.
Both banks feeding	Bad low pressure switch	Check for proper settings and replace as necessary.
	Loss of electrical power or loose connections on solenoid valves and pressure switches.	Check power supply. Check all electrical connections. Repair and replace faulty components as necessary.
	Possible blown fuse	Check for blown fuses in power supply box.
Gas leakage	Loose fittings, connections	Check and repair as necessary

LIMITED WARRANTY: Allied warrants for a period of one year from date of shipment that the products manufactured by Allied are free from defects in material and workmanship. Allied makes no warranty with respect to products manufactured by others and furnished hereunder, provided, however, Allied shall extend to Buyer any warranties, which it received, from such vendors. Items found to be defective will be covered under the warranty. The warranty will cover only the repair parts to correct the defective component.

In the event of breach of any warranty hereunder, Allied's sole and exclusive liability shall be its option either to repair or replace F.O.B. destination any defective products, or to accept return of such product and refund the purchase price; in either case provided that written notice of such defect is given to Allied within warranty period of product purchased, that the product is found by Allied to have been defective at the time of such shipment, that the product has been installed and/or operated in accordance with Allied's instructions, that no repairs, alterations or replacements have been made by others without Allied's written approval, and that Buyer notifies Allied in writing within forty-five (45) days after the defect becomes apparent and promptly furnishes full particulars in connection therewith, and provided further that in no event shall the aggregate liability of Allied in connection with breach of any warranty or warranties exceed the purchase price paid for the product purchased hereunder. Allied may, at its option, require the return of any product, transportation and duties prepaid, to establish any claim of defect made by Buyer. Allied will not accept and shall have no responsibility for products returned without its prior written consent and Allied will not assume any expense or liability for repairs to products. In the event Allied elects to replace a defective product, costs of installation, labor, service and all other costs to replace the product shall be the responsibility of Buyer. **EXCEPT AS EXPRESSLY STATED HEREIN, ALLIED MAKES NO WARRANTIES, EXPRESSED OR IMPLIED, AND DOES NOT WARRANT THAT THE PRODUCTS ARE MERCHANTABLE OR FIT ANY PARTICULAR PURPOSE.**

Allied shall not, except as set forth above, be otherwise liable to Buyer or to any person who shall purchase from Buyer, or use, any product supplied hereunder for damages of any kind, including, but not limited to direct, indirect, special or consequential damages or loss of production or loss of profits resulting from any cause whatsoever, including, but not limited to, any delay, act, error or omission of Allied.

Every claim from any cause shall be deemed waived by Buyer unless made, in writing, within twelve (12) months of the receipt by Buyer of the goods to which such claim relates. No legal proceedings will be brought for any breach of this contract more than one year after the accrual of the cause of action